

TOP VIEW

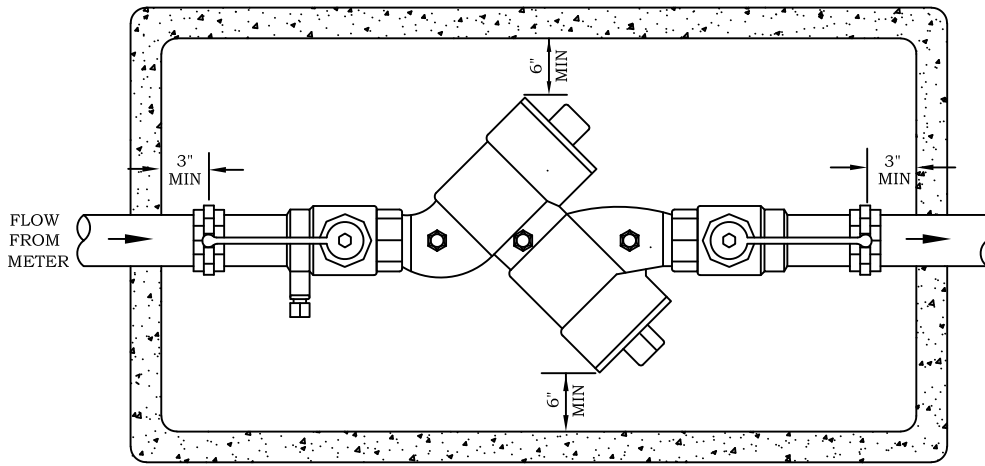

SIDE VIEW

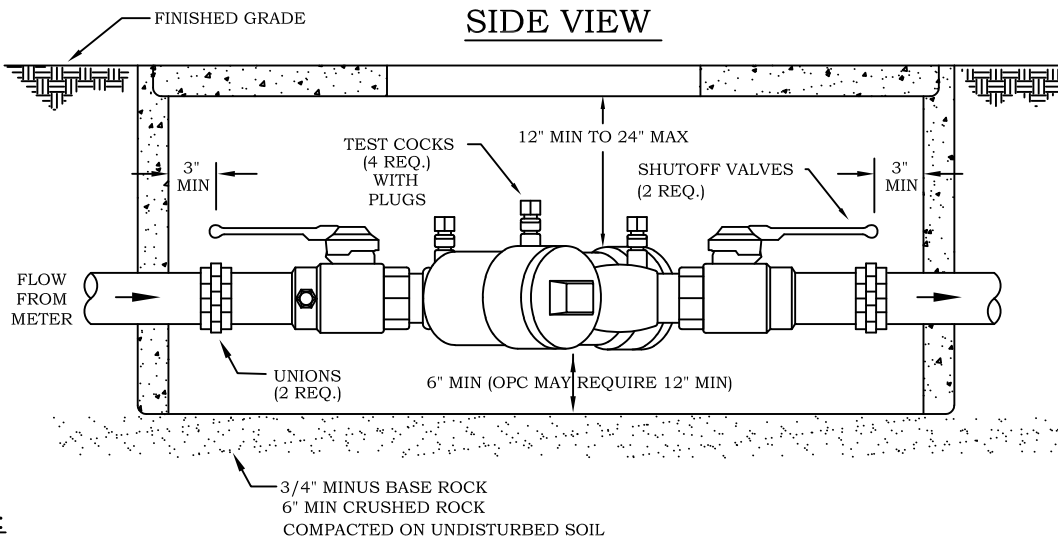

NOTES:

1. Double Check Valve Assembly:
 - a. shall be on the State of Oregon list of approved assemblies.
 - b. shall include factory supplied shut-off valves.
 - c. shall be installed in a location approved by MW&L.
 - d. may be installed vertically, provide the assembly is specifically listed for that orientation in the OHA list of approved assemblies.
2. All clearances apply to in-building and vault installations.
3. Assemblies installed below ground level shall have watertight, threaded plugs or caps installed on the cocks. The assembly shall not be subject to continuous immersion.
4. Typical assembly enclosure is a irrigation control box, or fabricated permanent enclosure.
5. For testing and maintenance purposes, the Assembly shall not be installed more than 5' above the ground or floor level, unless approved by MW&L and accompanied by a permanent OSHA-approved platform.
6. Shall be protected from freezing when necessary.

Permanent water service will not be granted until an initial Backflow Test Report is received by MW&L. Annual testing of assembly is required.

NOT TO SCALE



**DOUBLE CHECK VALVE ASSEMBLY
2" AND SMALLER**

DATE	REVISION	DATE	12/9/14		
		DRAWN	SLW	APPROVED	WSC
					SPEC NO. DCVA-2